



NEW HOLLAND

F170



NET FLYWHEEL POWER
- TIER 2 - EMISSIONED ENGINE
- NOT EMISSIONED ENGINE

127 kW - 170 hp
116 kW - 155 hp

OPERATING WEIGHT

14 550 KG

 **NEW HOLLAND**

CONSTRUCTION

BUILT AROUND YOU

F170 SPECIFICATIONS



OPERATING WEIGHT

Unit with coolant, hydraulic, full fuel tank, operator and ROPS cab
 On front wheels4250 kg
 On rear wheels10300 kg
 Total.....14550 kg



ENGINE TIER 2

Net flywheel power (SAE J1349)
 Emissioned - Tier 2127 kW/170 hp
 Not emissioned116 kW/155 hp
 Stated net flywheel power is delivered up to 2500 m a.s.l.

Make and model(Emissioned) Cummins 6 CTAA 8.3 Tier 2
 (Not emissioned) Cummins 6 CT 8.3
 TypeDiesel, 4 stroke, direct injection turbocharged
 Total displacement8.3 l
 N° of cylinders6
 Bore x stroke114 x 135 mm
 Rated engine speed(Tier 2 - emissioned) 2200 rpm
 (Not emissioned) 2300 rpm

Maximum torque:
 emissioned - 1400 rpm86 daNm
 not emissioned - 1300 rpm61 daNm



ELECTRICAL SYSTEM

Voltage24 V
 Batteries in series2
 Total capacity100 Ah
 Alternator capacity70 A



TRANSMISSION

Type: direct drive PowerShift, modulated shift on-the-go with inching pedal. Eight speed forward and four reverse.

Control: electric, single lever "bump type"

Speeds	Forward	Reverse
	km/h	km/h
1	3.6	3.6
2	5.1	7.2
3	7.2	14.3
4	10.0	28.5
5	14.3	-
6	20.0	-
7	28.5	-
8	43.0	-



TANDEM DRIVE HOUSING

Welded box section, wall thickness19 mm
 Chain pitch50.8 mm
 Interchangeable axles and sprockets, mounted on ball bearings.
 Tandem oscillation, each way20°



AXLE FRONT

High clearance, high strength welded steel construction with 19° oscillation each way.
 Wheel lean 18° right and left, hydraulically operated.
 Ground clearance622 mm



AXLE REAR

Heavy duty cast iron housing. Heat treated steel axles with tapered roller bearings.
 Ground clearance380 mm
 Super max-trac (limited slip) differential.



BRAKE SYSTEM

- **Service brakes:** Foot operated, hydraulically actuated, multiple sealed inboard wet-disc brakes.
- **Emergency brakes:** Each service system circuit is equipped with a nitrogen accumulator, ensuring brake efficiency with the engine off and operator warning system (visual and audible).
- **Parking brake:** Hand operated, caliper installed on transmission output shaft.



FRAMES

- Front frame
 Welded box298 x 254 mm
 Frame section weight173 kg/m
- Rear frame
 Welded box299 x 121 mm
 Frame section weight each side84 kg/m



DRAWBAR

Type "A" frame welded construction with centre mounted circle turn motor.
 Connections: shim-adjustable ball and socket.



CIRCLE

Outside diameter1753 mm
 Fabricated "T" section178 x 168 x 38 mm
 Degrees turn360°
 Wear surface, replaceable phenolic inserts.
 Total wear plate area2845 cm²
 Circle turn gears enclosed and running in oil.

F170

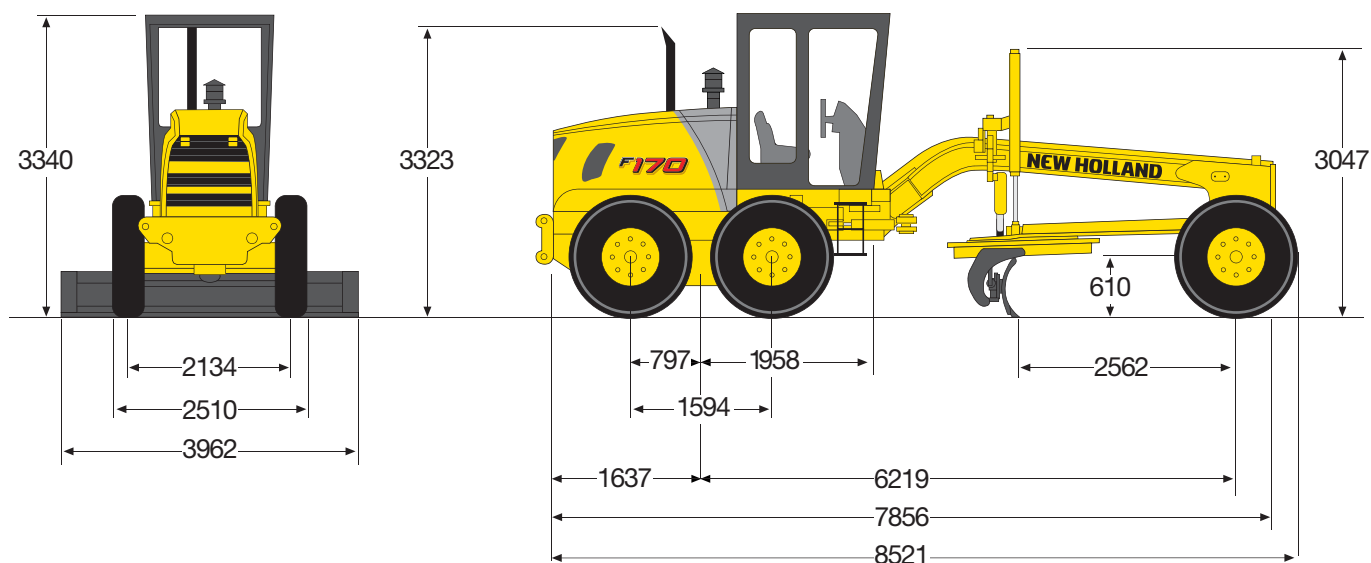

BLADE

One piece "Roll-Away", involute curve blade with replaceable end bits and cutting edges.

Hydraulic blade side shift and pitch.

Available sizes3962 x 671 x 22 mm
3658 x 622 x 22 mm
4267 x 671 x 22 mm

Lift above ground444 mm
 Blade side shift left533 mm
 Blade side shift right686 mm
 Blade penetration712 mm
 Reach outside wheels (STD blade, frame in stright position)*
 - left1735 mm
 - right1895 mm
 Blade pitch range.....backward 5°
 forward 40°

Bank cutting angle (left and right)90°
 Blade pressure
 - with ROPS cab.....7606 kg
 - with ROPS cab, ripper and front blade9356 kg
 * (with frame art. 25° + 684 mm L&R)

HYDRAULIC SYSTEM

Full hydraulic "Load Sensing" system with variable displacement piston pump, pressure and flow compensated control valve.

Blade lifting cylinder mounted on rotating saddle. Saddle locking controlled by 1 electro-hydraulic pin actuated from the dashboard.
 - max flow delivery186 l/min
 - max working pressure179 bar

STEERING

- Front wheels
 Typehydrostatic, orbitrol
 Pumpgear type
 Capacity at 2200 rpm44 l/min
 Cylinders2
 bore x stroke64 x 267 mm
 Wheel steer angle (left & right)48°
 - Articulated frame
 Hydraulic actuated articulation (left & right)25°
 Cylinders2
 bore x stroke80 x 377 mm
 Minimum turning radius7.3 m

TYRES

One set of the following heavy-duty tyres as listed below:
 13.00 x 24 (12PR)
 14.00 x 24 (10PR)
 14.00 x 24 (12PR)
 16.00 x 24 (12PR)
 17.50 x 25 (12PR)

CAPACITIES

Engine litres
 Fuel tank340.0
 Cooling system.....40.0
 Crankcase19.0
 Transmission19.0
 Tandem case each29.0
 Hydraulic tank95.0
 Rear axle.29.0
 Circle turn housing.....2.8

ATTACHMENTS

FRONT SCARIFIER

Type	parallelogram, front mounted
Weight (5 teeth)	570 kg
Width	1168 mm
Number of teeth	5 (std.) or 11 (opt.)
Width between teeth:	
- with 5 teeth.....	229 mm
- with 11 teeth.....	114 mm
Lift above ground	527 mm
Penetration.....	318 mm
Machine length with front scarifier	9380 mm

REAR RIPPER

Type	parallelogram, rear mounted
Weight.....	625 kg

Width	2340 mm
Number of teeth	5
Width between teeth	530 mm
Lift above ground	520 mm
Penetration.....	440 mm
Machine length with ripper/scarifier	9700 mm

DOZER BLADE

Type	front mounted
Weight	1165 kg
Dimensions.....	2762 x 953 mm
Lift above ground	622 mm
Penetration.....	165 mm
Machine length with dozer blade	9475 mm

STANDARD EQUIPMENT

- Adjustable operator's console
- Adjustable tilt steering wheel
- Air cleaner, automatic dust ejector
- Alternator - 70 Amp
- Antifreeze
- Back-up alarm
- Blade 3658 mm, 12' wide
- Blade side shift & pitch, hydraulic
- Controls, hydraulic: Articulation, Blade lift/lower, Blade side shift, Circle side shift, Circle turn, Front & rear attachment, Saddle lock, Wheel lean
- Electronic data monitor
- Engine side panels

- Engine TIER 1 or TIER 2 emission regulation
- Fan, with finger guard
- Gauges: Engine coolant temperature, Engine oil pressure, Fuel level, Transmission oil pressure, Transmission oil temperature
- Horn
- Light package: Moldboard work lights (2), Rear work light (2), Turn signals, stop, taillights & warning flashers
- Muffler
- Rear drawbar
- ROPS canopy with inside rear view mirror
- Saddle 3 points
- Tyres 14.00 x 24 (10PR)

OPTIONAL EQUIPMENT

- Additional hydraulic functions
- Air conditioning
- Blade 3960 mm
- Blade 4267 mm
- Blade extension, 600 mm each side
- Blade floatation control
- Blade rock bits
- Cab mounted flood lights (2)
- Cold weather starting aid
- Dozer blade floatation control
- Emergency steering
- Front counterweight
- Front pull hook
- Front push plate
- Outside rear view mirrors
- Piping for front attachment
- Piping for rear attachment

- Pressurised cab
- Rear axle with differential lock-unlock and wet disc brakes at the four tandems hubs.
- ROPS cab with: Dome light, Floor mat, Front/rear wipers 2 speed and windows washer, Heater, Inside rear view mirror, Sound suppression, Suspension seat, Seat belt, Tinted safety glass
- Rotation beacon/strobe light
- Saddle fixed
- Saddle 5 points
- Slow moving emblem
- Spare tyre
- Tyre 13.00 x 24 (12 PR), 14.00 x 24 (12PR), 17.50 x 25 (12PR)
- Tyre inflation
- Tool box
- Tool kit
- Vandalism protection
- Warning beacon

Note: standard and optional equipment may vary by country. Consult your NEW HOLLAND dealer for specific details.

AT YOUR OWN DEALERSHIP

The information contained in this brochure is intended to be a general nature only. The NEW HOLLAND KOBELCO CONSTRUCTION MACHINERY S.p.A. company may at any time and from time to time, for technical or other necessary reasons, modify any of the details or specifications of the product described in this brochure. Illustrations do not necessarily show products in standard conditions. The dimensions, weights and capacities shown herein, as well as any conversion data used, are approximate only and are subject to variations within normal manufacturing techniques.

Published by NEW HOLLAND KOBELCO CONSTRUCTION MACHINERY S.p.A. - www.newholland.com
Printed in Italy - LEADER Firenze - Cod. 73301 262GB - Printed 07/07



BUILT AROUND YOU

www.newholland.com