



NEW HOLLAND

F140



NET FLYWHEEL POWER

104 kW - 139 hp

OPERATING WEIGHT

13 535 kg



NEW HOLLAND

CONSTRUCTION

BUILT AROUND YOU

F140

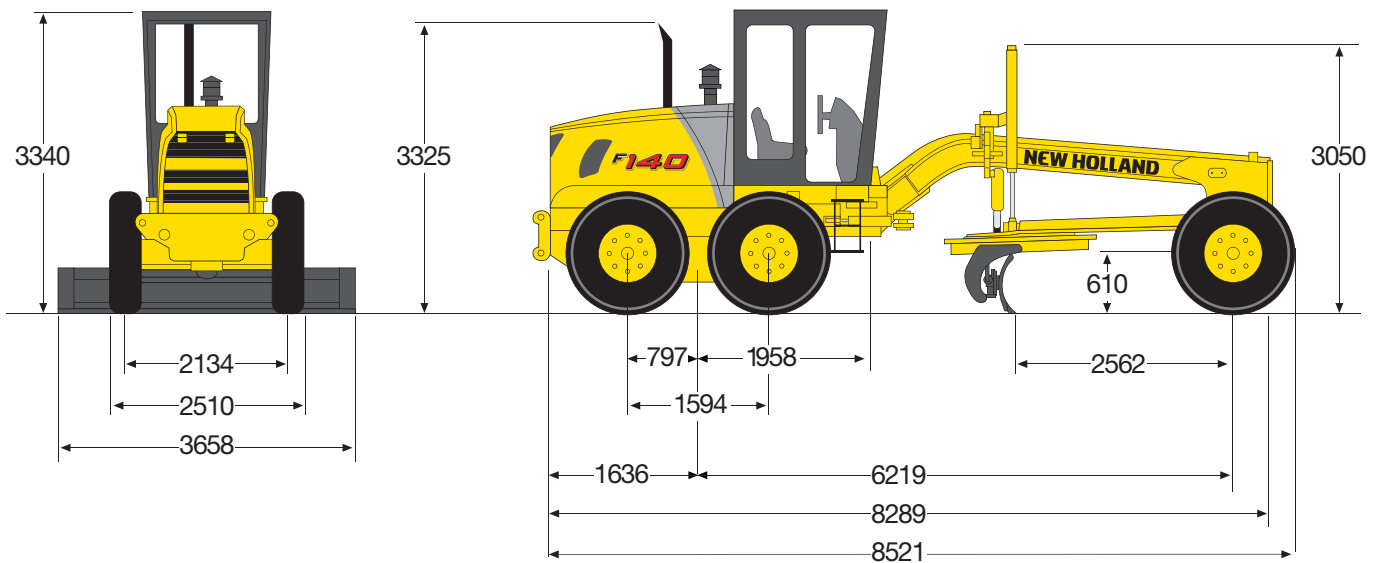

BLADE

One piece "Roll-Away", involute curve blade with replaceable end bits and cutting edges.

Hydraulic blade side shift and pitch.

Available sizes3658 x 622 x 22 mm
3962 x 671 x 22 mm
4267 x 671 x 22 mm

Lift above ground444 mm

Blade side shift left533 mm

Blade side shift right686 mm

Blade penetration712 mm

Reach outside wheels (STD blade, frame in stright position)*

- left.....1582 mm

- right1742 mm

Blade pitch range.....backward 5°
 forward 40°

Bank cutting angle (left and right)90°

Blade pressure

- with ROPS cab.....6635 kg

- with ROPS cab, ripper and front blade8636 kg

* (with frame art. 25° + 684 mm L&R)



STEERING

- Front wheels

Typehydrostatic, orbital

Pumpgear type

Capacity at 2200 rpm38 l/min

Cylinders2

bore x stroke63.2 x 266.7 mm

Wheel steer angle (left & right)48°

- Articulated frame

Hydraulic actuated articulation (left & right)25°

Cylinders2

bore x stroke80 x 377 mm

Minimum turning radius7.3 m



TYRES

One set of the following heavy-duty tyres as listed below:

13.00 x 24 (12PR)

14.00 x 24 (10PR)

14.00 x 24 (12PR)

16.00 x 24 (12PR)

17.50 x 25 (12PR)



CAPACITIES

Engine litres

Fuel tank340.0

Cooling system.....40.0

Crankcase14.2

Transmission25.0

Tandem case each30.0

Hydraulic tank94.6

Rear axle29.0

Circle turn housing.....2.8



HYDRAULIC SYSTEM

Full hydraulic "Load Sensing" system with variable flow gear pump and pressure and flow compensated control valve. Blade lifting cylinder mounted on rotating saddle. Saddle locking controlled by 1 electro-hydraulic pin actuated from the dashboard.

- max flow delivery192 l/min

- max working pressure179 bar

ATTACHMENTS

FRONT SCARIFIER

Type	parallelogram, front mounted
Weight (5 teeth)	570 kg
Width	1168 mm
Number of teeth	5 (std.) or 11 (opt.)
Width between teeth:	
- with 5 teeth.....	229 mm
- with 11 teeth.....	114 mm
Lift above ground	527 mm
Penetration.....	318 mm
Machine length with front scarifier	9457 mm

REAR RIPPER

Type	parallelogram, rear mounted
Weight.....	625 kg

Width	2340 mm
Number of teeth	5
Width between teeth	530 mm
Lift above ground	505 mm
Penetration.....	350 mm
Machine length with ripper/scarifier	9550 mm

DOZER BLADE

Type	front mounted
Weight	1165 kg
Dimensions.....	2762 x 953 mm
Lift above ground	622 mm
Penetration.....	165 mm
Machine length with dozer blade	9457 mm

STANDARD EQUIPMENT

- Adjustable operator's console
- Adjustable tilt steering wheel
- Air cleaner, automatic dust ejector
- Alternator - 70 Amp
- Antifreeze
- Back-up alarm
- Blade 3658 mm, 12' wide
- Blade side shift & pitch, hydraulic
- Controls, hydraulic: Articulation, Blade lift/lower, Blade side shift, Circle side shift, Circle turn, Front & rear attachment, Saddle lock, Wheel lean
- Electronic data monitor
- Engine side panels
- Engine TIER 1 or TIER 2 emission regulation
- Fan, with finger guard
- Gauges: Engine coolant temperature, Engine oil pressure, Fuel level, Transmission oil pressure, Transmission oil temperature
- Horn
- Light package: Moldboard work lights (2), Rear work light (2), Turn signals, stop, taillights & warning flashers
- Muffler
- Rear drawbar
- ROPS canopy with inside rear view mirror
- Saddle 3 points
- Tyres 14.00 x 24 (10PR)

OPTIONS

- Additional hydraulic functions
- Air conditioning
- Blade 3960 mm
- Blade 4267 mm
- Blade extension, 600 mm each side
- Blade floatation control
- Blade rock bits
- Cab mounted flood lights (2)
- Cold weather starting aid
- Dozer blade floatation control
- Emergency steering
- Front counterweight
- Front pull hook
- Front push plate
- Outside rear view mirrors
- Piping for front attachment
- Piping for rear attachment
- Pressurised cab
- Rear axle with differential lock-unlock and wet disc brakes at the four tandems hubs.
- ROPS cab with: Dome light, Floor mat, Front/rear wipers 2 speed and windows washer, Heater, Inside rear view mirror, Sound suppression, Suspension seat, Seat belt, Tinted safety glass
- Rotation beacon/strobe light
- Saddle fixed
- Saddle 5 points
- Slow moving emblem
- Spare tyre
- Tyre 13.00 x 24 (12PR), 14.00 x 24 (12PR), 17.50 x 25 (12PR)
- Tyre inflation
- Tool box
- Tool kit
- Vandalism protection
- Warning beacon

Note: standard and optional equipment may vary by country. Consult your NEW HOLLAND dealer for specific details.

AT YOUR OWN DEALERSHIP

The information contained in this brochure is intended to be a general nature only. The NEW HOLLAND KOBELCO CONSTRUCTION MACHINERY S.p.A. company may at any time and from time to time, for technical or other necessary reasons, modify any of the details or specifications of the product described in this brochure. Illustrations do not necessarily show products in standard conditions. The dimensions, weights and capacities shown herein, as well as any conversion data used, are approximate only and are subject to variations within normal manufacturing techniques.

Published by NEW HOLLAND KOBELCO CONSTRUCTION MACHINERY S.p.A. - www.newholland.com
 Printed in Italy - LEADER Firenze - Cod. 73301 261GB - Printed 07/07



BUILT AROUND YOU

www.newholland.com